

**Translation of original operating instruction  
Quadra® solar shading control unit for 8 sectors**

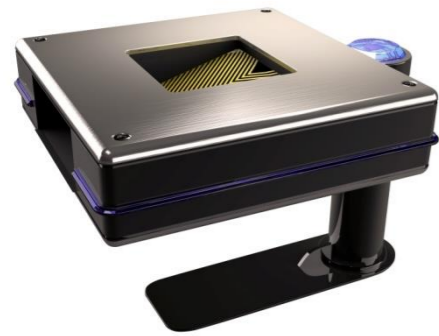

**1 General information**

**1.1 Notice**

This document is part of the product. Keep this operating instruction for future references.

**1.2 Scope of delivery**

Check the delivery according to the delivery note.

**Product designation**

Art.-Nr.	Description
0104001.XXX	Quadra® solar shading control unit for 8 sectors
	Mast extension (approx. 20 cm)
	Mast clamps
	Operating instruction

**1.3 Accessories**

Art.-Nr.	Description
0503001.XXX	PS24-1500 power supply 24V DC / 1500mA
0120001.XXX	Mast extension (approx. 35 cm)
1101001.XXX	KNX Touch-Display 3,5"

**1.4 Product description**

The Quadra® is a KNX solar shading control unit with integrated sensors for wind speed and wind direction (ultrasonic), brightness (north, east, south, west, sky), global radiation (north, east, south, west, sky), temperature (ultrasonic) and precipitation.

Up to 8 sectors can be controlled with the Quadra®. Comfort (shading, temperature, heat, twilight, lighting, time, input) and security programs (wind, precipitation, frost, global radiation) are available for this.

**1.5 Limitations of liability**

All information and notes in this operating instruction has been compiled in consideration of the applicable standards and regulations, the state of the art as well as our many years of knowledge and experiences.

The manufacturer assumes no liability for damages and operational malfunction due to

- disregarding this operating instruction
- improper use
- faulty connection
- non-use of original spare parts and accessories

**1.6 Disposal**

The disposal of this product in normal household waste is forbidden within the European Union.

Dispose of the device via the municipal collection points.

The packaging materials used are recyclable. Dispose of packaging materials that are no longer required according to local regulations.

**1.7 Copyright**

This documentation is protected by copyright.

All rights reserved, including those of photomechanical reproduction, copying and distribution by means of special procedures (e.g. data processing, data carriers, and data networks), even in parts. Subject to technical changes and alterations in content.

**1.8 Manufacturer/ Customer service**

**BMS – Building Management Systems**

Heinrich-Heine Straße 3  
47906 Kempen  
Germany

Phone: +49 (0) 2152 / 95 989 – 0

Fax: +49 (0) 2152 / 95 989 – 9

E-Mail: [info@bms-solutions.de](mailto:info@bms-solutions.de)

Internet: [www.bms-solutions.de](http://www.bms-solutions.de)

**2 Safety**

**2.1 Intended use**

The Quadra® solar shading control unit captures the weather data and sends the control commands to the actuators/ motor control units in a KNX system within the specified limits.

Any other use or extended use is considered to be improper.

Implicitly handle the device with the care usual for measuring instruments!

**2.2 Foreseeable misuse**

Any use for a purpose other than the above mentioned purpose is improper. The risk of improper use or misuse is borne solely by the operator.

All types of claims due to damage arising from improper use are excluded.

**2.3 Personnel's qualification**

Improper use can cause considerable personal injury and material damage!

All tasks for installation, connection and commissioning must be carried out exclusively by a qualified electrician.

A qualified electrician is able to carry out work on electrical installations due to her/ his professional training, knowledge, and experience as well as knowledge of the relevant standards and regulations. She/ he can identify and avoid possible dangers.

The qualified electrician is trained for the specific place of employment in which she/ he is working and is aware of the relevant standards and regulations.

**2.4 Basic safety instructions**

	<b>⚠ DANGER</b>
	<p><b>Danger of life!</b> There is a risk of life when touching live parts.</p> <ul style="list-style-type: none"> <li>▶ All tasks must be carried out exclusively by qualified personnel.</li> <li>▶ Disconnect all power supplies before starting work.</li> </ul>

	<b>CAUTION</b>
	<p><b>Material damage!</b> Incorrect wiring and configuration of the device can lead to damage up to total failure.</p> <ul style="list-style-type: none"> <li>▶ Ensure that the supply voltage corresponds to the specifications from the technical data for the device.</li> <li>▶ Refer to the software-helpfile for details on the configuration.</li> </ul>

**2.5 Signage**

Symbol	Meaning
	General warning
	Electrostatic discharge
	CE label

**3 Design and function**

**3.1 Complete overview**

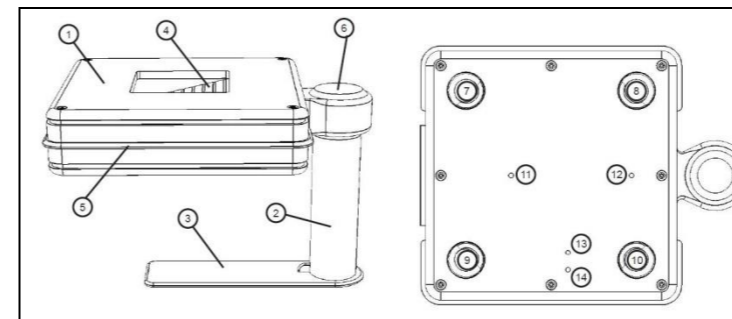

**Location of functional elements**

- 1 Main housing
- 2 Mast tube
- 3 Reflector plate
- 4 Precipitation sensor
- 5 Light conductor with brightness/ global radiation sensors (north/ east/ south/ West)
- 6 Brightness/ global radiation sensor sky
- 7-10 Ultrasonic sensors
- 11 Temperature sensor
- 12 Status-LED (green)
- 13 Programming-LED (red)
- 14 Programming button

**3.2 Control and display elements**

**Status-LED**

- flashes with a frequency of 1 Hz during standard operation
- flashes 3x rapidly every second, if the KNX bus voltage is missing or the application has not been programmed
- lights continuously "GREEN", if the device does not start up correctly

**Programming button**

- activates/ deactivates the programming mode (supply voltage and KNX bus voltage must be available)

**Programming LED**

- lights continuously "RED" when the programming mode is activated

**4 Installation**

**4.1 Mounting position**

When choosing the mounting position the following requirements have to be regarded.

- no shadow on the device at any time, this would influence the brightness measurement

	<b>NOTICE</b>
	<p>To avoid reflections with the ultrasonic measurement (wind speed, wind direction, air temperature) the minimum distances (min. 50 cm to all directions) to surrounding parts and devices have to be kept in.</p>

- free flow for a correct wind measurement without influence by wind turbulences / wind shadow / exhaust airstreams
- mast mounting is always preferable to a wall mounting; wall mounting can lead to a shadow throw on the device; backpressure and wind shadow can cause wrong wind measurements
- DO NOT mount on building corners; wind turbulences can cause wrong wind measurements
- DO NOT mount under a roof overhang; precipitation can not be detected and there can be shadow on the device
- DO NOT mount in the surrounding of radio masts; the measuring electronics can be disturbed

**4.2 Mounting**

To mount the device proceed as follows

- choose suitable mounting position
- fix mast clamps
- lead the cable through the mast extension and screw the mast extension on the threaded pin WITHOUT any tool; if necessary, several mast extensions can be screwed together using the thread adapter supplied

	<b>NOTICE</b>
	<p>DO NOT use any tools to mount the mast extensions! Due to the low thread pitch (M22x1), a hand-tight fastening is sufficient. Only touch the mast pipe but not the main housing or the reflector plate of the Quadra®.</p>

- put the Quadra® with the mast extensions into the mast clamps, close the clamps and fasten them with the screws – take care of the orientation

	<b>NOTICE</b>
	<p>Mount the Quadra® with the mast into northern direction (see illustration). Otherwise the orientation has to be adjusted inside of the ETS application. To change the mechanical orientation always loose the mast clamps.</p>

- North – 0°
- East – 90°
- South – 180°
- West – 270°

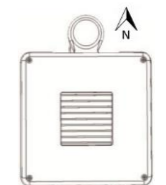

### 4.3 Electrical connection

#### Overview

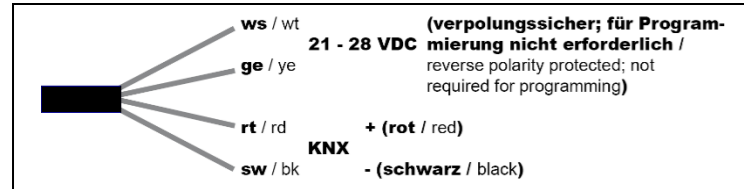

#### Wiring diagram

#### KNX bus

Connect the KNX bus to the solar shading control unit according to the wiring diagram.

#### Supply voltage

Connect the supply voltage to the solar shading control unit according to the wiring diagram. The connection for the supply voltage is reverse polarity protected.

**NOTICE**  
Use suitable terminals to connect flexible and rigid cables.

### 4.4 Configuration

The configuration of the solar shading control unit is done via ETS from version 3.0f of KNX-Association.

**NOTICE**  
For details about the configuration software see documentation of KNX-Association.

#### Requirements

- KNX bus voltage must be present

#### Approach

- ➡ connect PC/Laptop to the KNX bus via programming interface
- ➡ set the solar shading control unit to programming mode by pushing the programming button
- ↔ the programming LED lights continuously "RED"
- ➡ download the physical address and the application program

**NOTICE**  
When the Quadra® solar shading control unit starts up all automatic programs are active.

### 4.5 Commissioning/ Test run

For commissioning of the solar shading control unit proceed as follows

- check the condition of the device and the tight attachment of the terminals and connections
- remove protective covers
- switch on supply voltage and KNX bus voltage
- check supply voltage, KNX bus voltage and status display on the device

**NOTICE**  
Correct setting of date, time and mounting position is necessary for the calculation of sun position and shading control.

- check date and time (read request via objects 1+2 – send date/ time) – if necessary adjust via objects 3+4 – receive date/ time
- mount all protective covers
- maintain system documentation and, if necessary, affix labels and/ or signs

## 5 Operation

### 5.1 User control

For user control of the Quadra® solar shading control unit the KNX Touch-Display is available. Alternatively, a KNX visualization can be used. This way it is possible to control sectors, to switch programs on/ off, to change limit values and to display measuring and error values.

### 5.2 Automatic operation

Automatic operation is performed according to the parameters specified in the ETS configuration. The control commands (input programs, measuring values) received via the KNX bus and the measured values as well as the hysteresis and time delays are considered.

## 6 Troubleshooting

**NOTICE**  
If the listed troubleshooting procedures do not lead to the desired result, contact the customer service.

Fault	Rectification
device does not communicate via KNX	<ul style="list-style-type: none"> <li>• check KNX bus voltage (programming LED can be switched on and off via the programming button)</li> <li>• check supply voltage (status LED flashes "GREEN" with a frequency of 1 Hz)</li> </ul>
measuring value is not send via KNX	<ul style="list-style-type: none"> <li>• check KNX bus voltage and supply voltage</li> <li>• check error object via KNX</li> <li>• check configured transmission behaviour (on change and periodically)</li> </ul>
date/ time incorrect	<ul style="list-style-type: none"> <li>• adjust date/ time via objects receive date/ time (possibly via Touch-Display)</li> <li>• the Quadra® has got a buffered real time clock (no time receiver)</li> </ul>
azimuth/ elevation incorrect	<ul style="list-style-type: none"> <li>• check date/ time and location coordinates and possibly adjust them</li> </ul>
precipitation signal/ alarm permanently on	<ul style="list-style-type: none"> <li>• check error object via KNX</li> <li>• check precipitation sensor for pollution and possibly clean it</li> </ul>
precipitation signal toggles	<ul style="list-style-type: none"> <li>• the precipitation signal is the raw sensor data, which is influenced by the heating</li> <li>• inside of the precipitation program the signal is debounced by on/ off time delays</li> </ul>
wind value/ alarm incorrect	<ul style="list-style-type: none"> <li>• check error object via KNX</li> <li>• check for pollution (e.g. cob web, icicles) in the area between the ultrasonic sensors and the reflector plate and possibly clean</li> <li>• make sure that the reflector plate is not damaged or moved</li> <li>• follow advices about mounting position</li> </ul>
brightness values incorrect	<ul style="list-style-type: none"> <li>• check error object via KNX</li> <li>• check configured transmission behaviour (on change and periodically)</li> <li>• check configured orientation of the Quadra® and the resulting sensor assignment</li> </ul>

**NOTICE**  
When the elevation rises above 30° the brightness values N, S, W, E decrease. The limit value set in the shading program normally refers to a mean value and is not directly related to a specific sensor value.

## 7 Maintenance/ Care

**NOTICE**  
The device must be subjected to a visual inspection at least every six months. In the case of damage, a permanently reliable operation is no longer ensured and the device has to be put out of operation.

**NOTICE**  
Pollution must be promptly eliminated in order to ensure perfect operation. For this, lukewarm water can be used.

## 8 Technical data

General		
Operating environment	Outside mounting	
Operating temperature	-15 ... +60	°C
Storage temperature	+10 ... +75	°C
Mounting	use original spare parts/ accessories (mast extensions/ mast clamps)	
Dimensions (W x H x D)	157 x 132 x 198	mm
Weight	900	g

**NOTICE**  
The connection and the wiring of the local operation units and the KNX bus must be carried out according to the current SELV requirements.

Connection data		
Supply voltage	21 ... 28	V <sub>DC</sub>
	only use original accessories	
Power consumption (without heating)	2,5	W
Heating current (controlled)	max. 1,3	A
KNX bus	According to KNX standard	
Bus current	max. 25	mA
Connection cable	2 x 2 x 0,25	mm <sup>2</sup>
	fine wire	
	2,5	m
Degree of protection	IP X4	
Protection class	III	

Sensors		
Temperature	-40 ... +60	°C
Brightness	0 ... 100	kLux
Global radiation	0 ... 1200	W/m <sup>2</sup>
Twilight	0 ... 1000	Lux
Wind speed	0 ... 35	m/s
Wind direction	0 ... 359	°
Precipitation	yes/ no	